

SJ45 T+

TELESCOPIC BOOM



STANDARD FEATURES

- EASYDRIVE™ Direction sensing drive and steer controls
- AXLDRIVE™ Axle-based 4WD system
- Operator controlled locking rear differential and limited slip front differential
- Oscillating steer axle
- Drivable at full height
- 40% Gradeability
- Wet disc SAHR brakes (Front and rear axle)
- Grip lug solid tyres
- Dual module control system with SKYCODED™ colour coded and numbered wiring
- SMARTORQUE™ Kubota D1305 Stage V diesel engine
- Swing up cowlings for easy access
- Proportional controls
- 272/454 kg Dual capacity
- 0.91 x 2.44 m Platform
- Bolt-in platform railings
- Lanyard attachment points
- Tri-entry sliding mid-rail
- Secondary Guarding Electrical (SGE)
- Overload sensing system
- Wiring for AC outlet on platform
- Tilt alarm (5.0° x 5.0°) with drive and lift cut-out
- Single point emergency lowering
- 360° Continuous turret rotation
- Tie down/lifting lugs
- Hourmeter
- Operator horn
- Lockable power disconnect switch

ACCESSORIES

- Glazier kit
- Pipe rack
- Tool caddy

OPTIONS

- Flashing light
- All motion audible alarm
- 0.91 x 1.83 m Platform
- Side spring hinged entry gate
- Auxiliary top rail (0.91 x 2.44 m platform only)
- 3.5 kW Generator
- Control box cover
- Grip lug solid non-marking tyres
- Cold weather start kit*

*Recommended for regions where average monthly low temperatures can reach -10°C (Includes cold start engine oil, battery blanket, and hydraulic tank heater)

- Arctic weather package*
*Recommended for regions where average monthly low temperatures can reach -18°C (Includes arctic engine oil, battery blanket, hydraulic tank heater, block heater, arctic hydraulic oil, and arctic gear oil in the axles and swing drive. Glow plugs, arctic hydraulic hoses (all), arctic platform rotator and oversized foot switch cover are also included (standard equipment).)
- ECOSTART (anti-engine idle)
- Diesel scrubber
- Bio oil
- ELEVATE telematics

Preliminary specifications at time of printing.

† Standard lead times may be increased when optional equipment is added, consult factory.

‡ Capacities and machine weights may differ when options are added.



ENG 05/2021

SKYJACK
simply reliable

SJ45 T+ TELESCOPIC BOOM

Dimensions	SJ45 T+
Work Height	15.75 m
Platform Height	13.75 m
Horizontal Reach	12.10 m
Working Reach	12.75 m
A Platform Size	0.91 x 2.44 m
B Stowed Width	2.29 m
C Tailswing	1.12 m
D Stowed Height	2.40 m
E Transportation Height	2.92 m
F Stowed Length	8.83 m
G Transportation Length	6.99 m
H Wheelbase	2.44 m
I Ground Clearance	0.27 m

Specifications	SJ45 T+
Rotation	360° Continuous
Platform Rotation	170°
Jib Length	1.52 m
Jib Range +/-	+65° / -60°
Weight	7,160 kg
Gradeability	40 %
Turning Radius (Inside)	2.24 m
Turning Radius (Outside)	5.18 m
Axle Oscillation	12.70 cm
Drive Speed (High speed)	4.0 km/h
Capacity	272 / 454 kg
Maximum wind rating	12.5 m/s
Personnel Rating at Max Wind Rating	2 / 3
Tyre Size	10 x 31
Tyre Type	Solid
Diesel Engine	Kubota D1305 18.5 KW (24.8 HP)
Fuel Tank Capacity	170 L
Hydraulic Reservoir	223 L

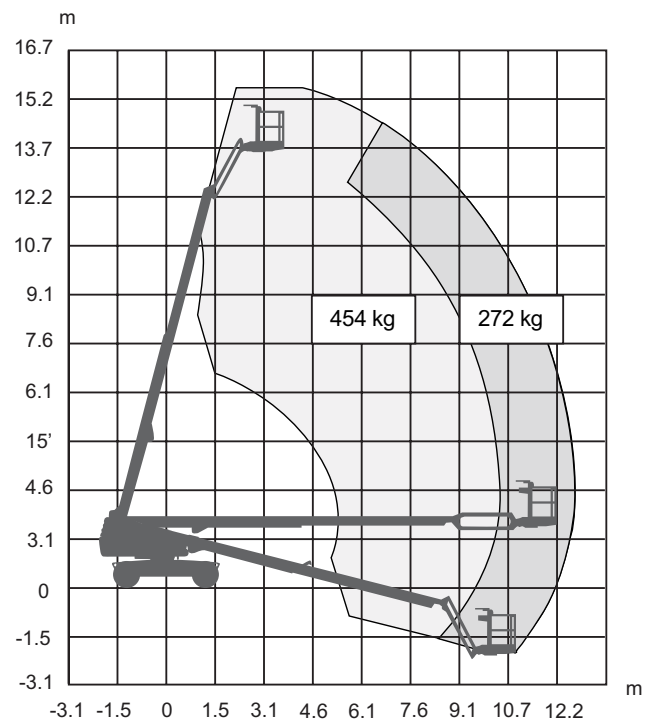
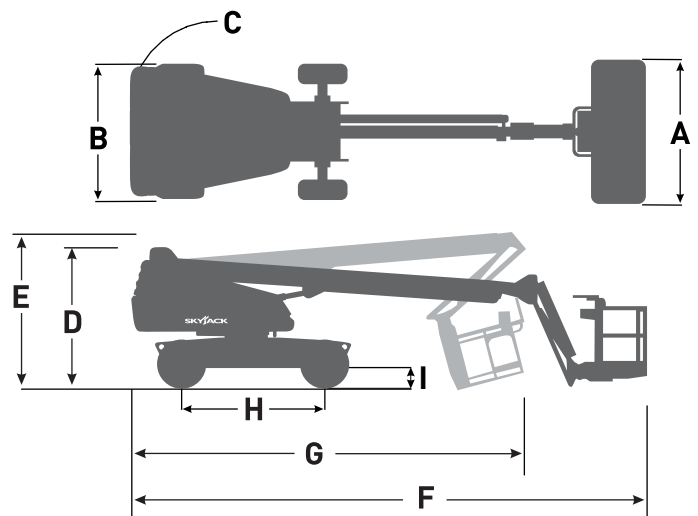

SJ45 T+ WORKING ENVELOPE

www.skyjack.com

Skyjack UK
 Unit 1, Maes-y-Clawdd
 Maesbury Road Industrial Estate
 Oswestry, Shropshire, SY10 8NN
 Tel: +44 1691 676235
 Fax: +44 1691 676239
 Email: info@skyjackeurope.co.uk

Skyjack SAS (France)
 74 Rue Sibert
 F-42400 Saint Chamond
 France
 Tel: +33 (0) 4 78 73 53 32
 Fax: +33 (0) 4 78 56 52 42

Skyjack Hebebühnen GmbH (Germany)
 Därmannsbusch 2a
 D-58456 Witten
 Tel: +49 (0) 2302 20 26 909
 Fax: +49 (0) 2302 20 25 671

Skyjack AB (Sweden)
 Agnesbergsvägen 28
 424 38 Agnesberg
 Sweden
 Tel: +46 (0) 31 21 22 45
 Fax: +46 (0) 31 787 65 10

SKYJACK
 simply reliable