

# SJ4740

## ELECTRIC SCISSORS



### STANDARD FEATURES

- Drivable at full height
- Integrated SKYCODED™ control and overload system
- On-board visual interface with diagnostic capabilities
- Standard Skyjack colour coded and numbered wiring
- Shroud style, impact resistant composite control box with extended cable
- Proportional controls for drive and lift functions
- Tilt alarm (3.5° x 1.5°) with drive and lift cut-out
- Swing out cabinets for easy access
- 24V DC Power with low voltage battery protection
- Universal smart charger
- Variable speed, front two wheel hydraulic drive
- Solid rubber, non-marking tyres
- 25% Gradeability
- Dual SAHR holding brakes
- 0.91 m Roll out extension deck
- Fold down hinged railings
- Half height spring hinged entry gate
- Lanyard attachment points
- Wiring for AC outlet at platform
- Pothole protection system
- Forklift pockets and tie down / lift lugs
- Single point emergency lowering
- Arm guard with slow close descend
- Flashing light
- Operator horn
- Telematics ready

### OPTIONS

- Light duty pipe rack
- Heavy duty pipe rack
- Board carrier
- Tool caddy
- All motion audible alarm
- Dual flashing lights
- AGM Batteries (140 Ah)
- Lockable swingout trays
- Full height spring hinged entry gate
- Bio oil
- Secondary Guarding Lift Enable (SGLE)
- ECOTRAY leak containment system
- ELEVATE telematics
- ELEVATE Battery Management System (BMS)\*

† Standard lead times may be increased when optional equipment is added, consult factory.

‡ Capacities and machine weights may differ when options are added.

\* Only available with ELEVATE telematics

# SJ4740 ELECTRIC SCISSORS

Dimensions	SJ4740
<b>A</b> Work Height	13.86 m
<b>B</b> Raised Platform Height	11.86 m
<b>C</b> Lowered Platform Height	1.41 m
<b>D</b> Overall Width	1.19 m
<b>E</b> Overall Length (Platform Retracted)	2.40 m
<b>F</b> Stowed Height (Rails Up)	2.53 m
<b>G</b> Stowed Height (Rails Down)	2.03 m
<b>H</b> Platform Width (Inside Railing)	1.06 m
<b>I</b> Platform Inside Length (Retracted)	2.19 m
Specifications	SJ4740
Extension Deck (Roll Out)	0.91 m
Ground Clearance (Pothole Raised)	11.4 cm
Ground Clearance (Pothole Deployed)	1.3 cm
Wheelbase	1.85 m
Weight	2,970 kg
Gradeability	25%
Turning Radius (Inside)	0.45 m
Turning Radius (Outside)	2.51 m
Lift Time (With Rated Load)	68 sec
Lowering Time (With Rated Load)	47 sec
Drive Speed (Stowed)	3.0 km/h
Drive Speed (Raised)	0.8 km/h
Maximum Drive Height	Full Height
Capacity (Overall)	350 kg
Distributed Capacity (Main Platform)	230 kg
Distributed Capacity (Extension Deck)	120 kg
Local Floor Load (With Rated Load)	956 kN/m <sup>2</sup>
Overall Floor Load (With Rated Load)	1,150 kg/m <sup>2</sup>
Maximum # of Persons at 0 m/s wind rating	3
Maximum # of Persons at 12.5 m/s wind rating	0
Tyre Type	Solid, N/M
Tyre Size	16 x 5 x 12

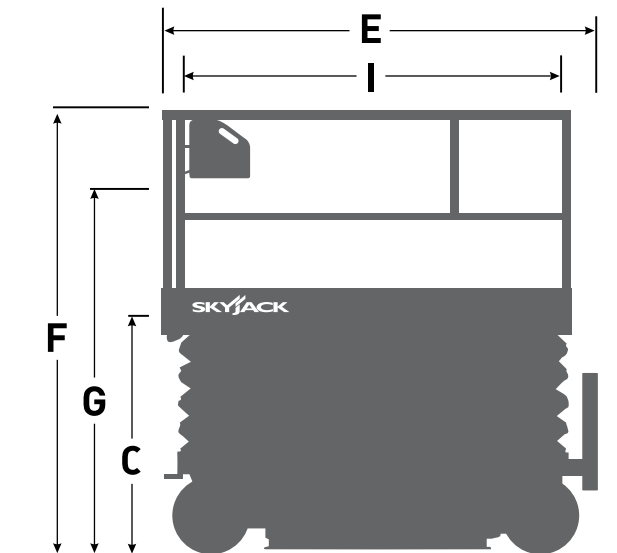
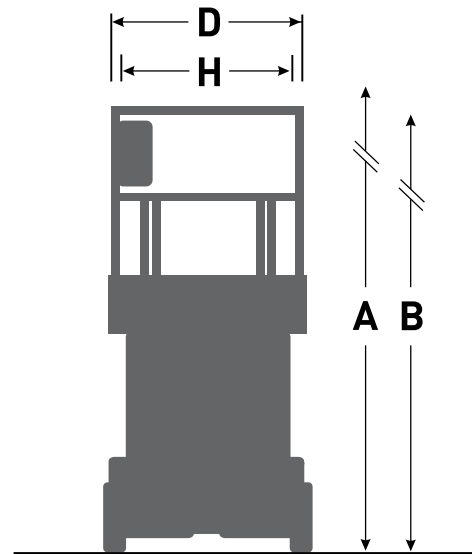

[www.skyjack.com](http://www.skyjack.com)

Skyjack UK  
Unit 1, Maes-y-Clawdd  
Maesbury Road Industrial Estate  
Oswestry, Shropshire, SY10 8NN  
Tel: +44 1691 676235  
Fax: +44 1691 676239  
Email: [info@skyjackeurope.co.uk](mailto:info@skyjackeurope.co.uk)

Skyjack SAS (France)  
74 Rue Sibert  
F-42400 Saint Chamond  
France  
Tel: +33 (0) 4 78 73 53 32  
Fax: +33 (0) 4 78 56 52 42

Skyjack Hebebühnen GmbH  
(Germany)  
Därmanbusch 2a  
D-58456 Witten  
Tel: +49 (0) 2302 20 26 909  
Fax: +49 (0) 2302 20 25 671

Skyjack AB (Sweden)  
Agnesbergsvägen 28  
424 38 Agnesberg  
Sweden  
Tel: +46 (0) 31 21 22 45  
Fax: +46 (0) 31 787 65 10

**SKYJACK**  
simply reliable