

# VERSALIFT

## VDT-170-F

Chassis mounted  
telescopic platform



PTO driven hydraulic pump



XPC controls with up to 4 actions at a time



Turret tailswing within the mirrors



Outriggers within the mirrors



1 kV certified low voltage insulation



# VERSALIFT

A **TIME** MANUFACTURING COMPANY

# VDT-170-F on MAN TGL



Due to the lift's unique design, there is plenty of room on the flatbed for goods or even a toolbox.

Booms are fabricated from high strength steel providing the most stable and safe cage experience available on the market.

■ Length: 7,085 mm ■ Height: 3,800 mm ■ Wheelbase: 3,600 mm



## Diagramme(s)

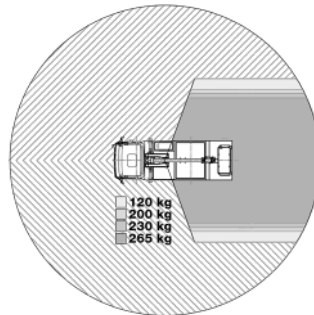
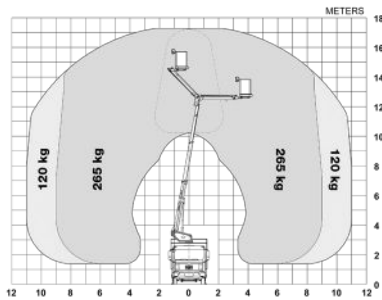

## Options

- Hydraulic axle locking system
- Workshop interior
- Bucket rotator (2 x 85°)
- Extended bucket (replaces standard bucket)
- Outrigger pads with holders
- Limited working area without outriggers
- Drive option (drive the vehicle with raised platform)



e-Tech battery solution



H-frame outriggers



Workshop interior (optional)



XPC controls with up to 4 actions at a time (2 per joystick)

## Notes

Technical information is subject to change without prior notice. Images may show optional equipment. Installations and/or options may not be available in your specific region.

- \* Depending on the vehicle.
- \*\* Max payload with a driver, a passenger and a full tank of fuel (260 kg added to the installation weight).
- \*\*\* Reduced outreach and max 230 kg bucket capacity.
- \*\*\*\* Requires the option "Limited working area without outriggers".

## Distributor

Versalift International  
Soendervang 3, 9640 Farsoe  
Denmark

+45 9863 2433  
sales@versalift.dk  
versaliftinternational.com